

# Alignment Systems



For checking and setting, straightness, alignment, verticality, parallelism, flatness, squareness & level

# The Micro Alignment Telescope

## Solving problems of alignment

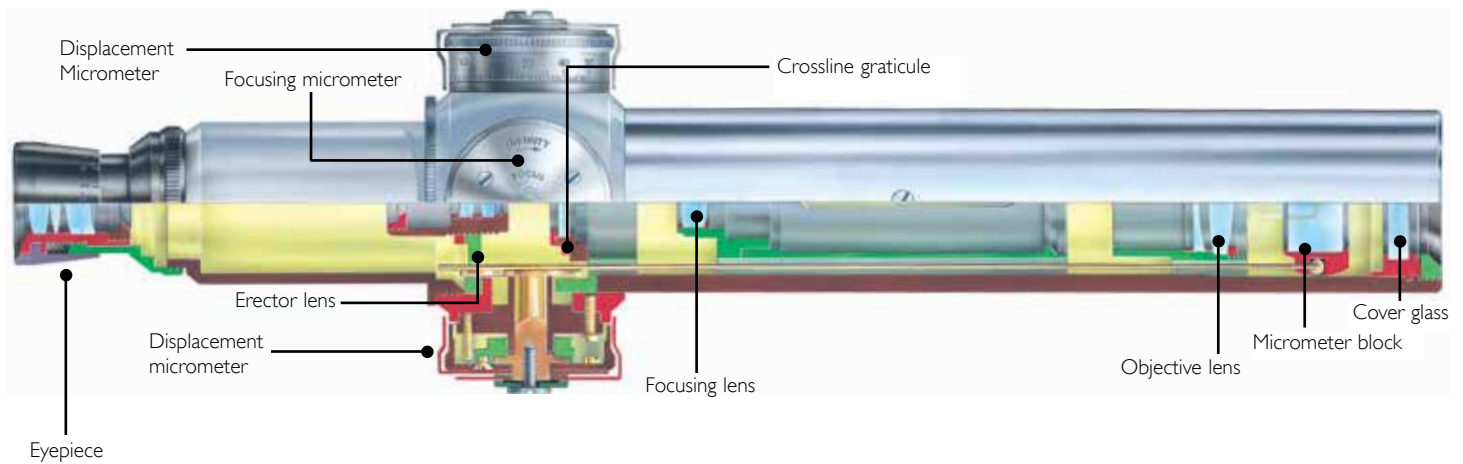

Since the late 1930s Taylor Hobson has sold thousands of alignment telescopes to industries throughout the world. The Micro Alignment Telescope is used to set and check alignment, squareness, straightness, flatness, parallelism, verticality and level.

With its wide range of accessories the Micro Alignment Telescope forms a unique and comprehensive system for solving alignment problems in a wide variety of applications and industries.



ViVi camera up to x8 (code 137-2161-01)

### The Micro Alignment Telescope system:

- Is simple and easy to use
- Is versatile and adaptable
- Enables improved product performance
- Enables reliable, accurate installation
- Reduces warranty and maintenance costs
- Is robust, reliable and portable
- Can be digitised

### The Micro Alignment Telescope has:

- Optical and Mechanical axes aligned to within 3 seconds and concentric within 6  $\mu\text{m}$  (0.00025 in)
- Achievable accuracy within 0.05 mm at 30 m (0.002 in at 100 ft)
- Field of view: 50 mm at 2 m (2 in at 6.5 ft)  
600 mm at 30 m (24 in at 100 ft)



Digital Alignment Telescope (code 112-3389)

# Principles of alignment

The basic measurement principles available with the Micro Alignment Telescope system are alignment, squareness, flatness, autocollimation and autoreflection. The Micro Alignment Telescope generates a straight line of sight from zero to infinity. This forms the basic reference from which all measurements are taken.

To measure squareness a penta prism is used to deviate the straight line through exactly 90 degrees. A similar rotating pentaprism is used to generate a plane for flatness measurement.

The Telescope is designed to allow autocollimation and auto-reflection, providing for squareness and angular measurement using reflective mirror targets.

A comprehensive range of accessories allow the telescope, targets and prisms to be mounted to the work concerned.

## Principle 1 – Alignment

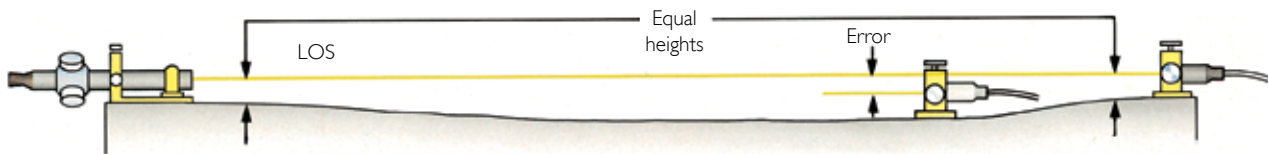

## Principle 2 – Squareness

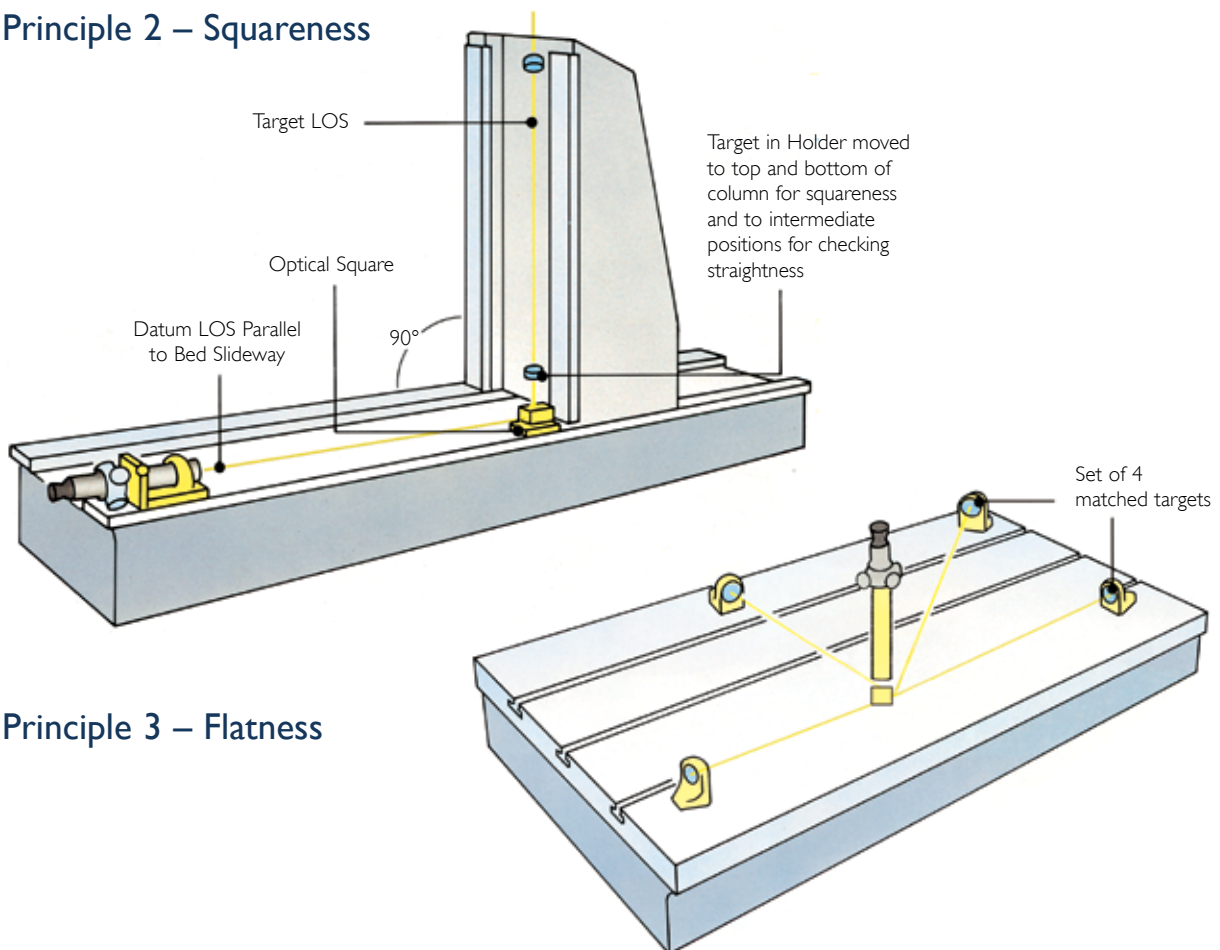

## Principle 3 – Flatness

# Alignment checks

(externally and internally)

## Typical applications

- Alignment of periscope bearings using the main bearing in the hull of the submarine as the datum
- Alignment of diesel engine bearings and boring bar
- Checking straightness of gun barrels using a digital MAT and sliding a target on a sledge along the inside of the gun barrel and its rifling.



Diesel engine alignment  
(shown here using camera system 137-2161-01)

## Typical equipment used\*

- Micro Alignment Telescope (112-2582 or 112-2583)
- Adjusting Bracket (112-5817)
- Bore Fixture (112-5814)
- Mounting Sphere (112-376 or 112-5823)
- Right Angle Eyepiece (112-568)
- Spider Fixture (137-5813)
- Target Illuminator (112-5923)
- Targets

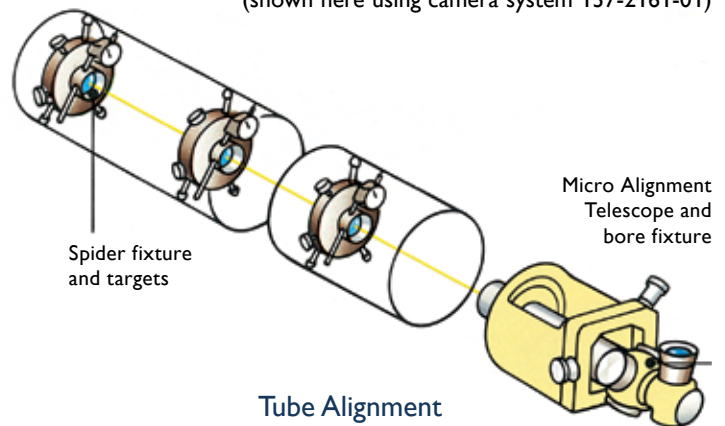

# Squareness and parallelism measurement

## Typical applications

- Rollers must be parallel and in some cases horizontal to eliminate damage to paper or other materials being processed.
- Vertical Presses: the movement of a press must be square to its main slideway. This is achieved by using an optical square to produce a square reference line to the main machine slideway.
- Weapons Harmonisation: weapons systems have a number of features that all must be set parallel to each other.

## Typical equipment used\*

- Micro Alignment Telescope (112-2582 or 112-2583)
- 4in Offset Square (112-1130)
- Unimount (137-1916)
- Universal Stands (112-5825 or 112-5824)

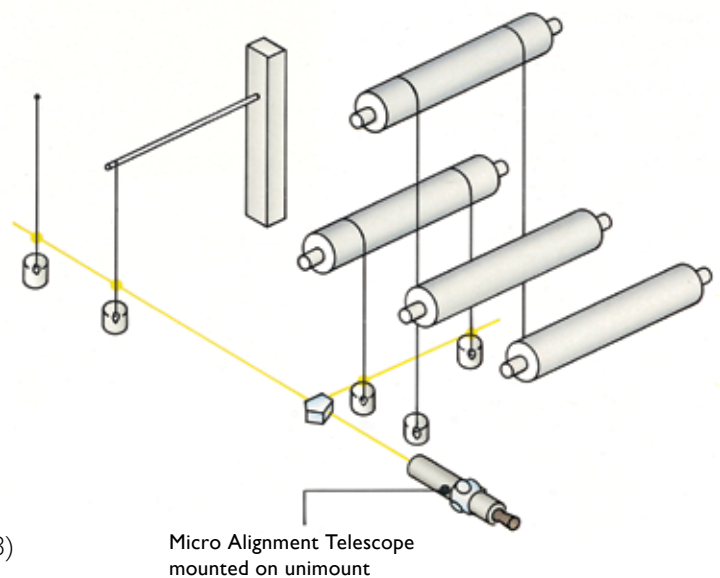

Squareness of rollers

# Horizontal and vertical measurement

## Typical applications

- The line of sight of the Alignment Telescope is parallel to its mechanical axis. Hence by using an electronic level it can be set truly horizontal. If two lines are set horizontal then they are parallel in at least one direction.
- Platforms for satellites: two platforms are set first in line then (using optical squares) set parallel to each other.
- The Alignment Telescope can be set both horizontally & truly vertically – this feature can be used to great effect in the nuclear industry.



## Typical equipment used\*

- Micro Alignment Telescope (112-2582 or 112-2583),
- Horizontal Base (112-5820), Adjusting Bracket (112-5817),
- Flange Cup (112-471), Mounting Sphere (112-376 or 112-5823),
- Talyvel® (M112-4515), Stride Base (112-2315)
- Sphere Clamp (112-657), Flange Cup (112-471)
- Target (various) and illuminator (112-5923)

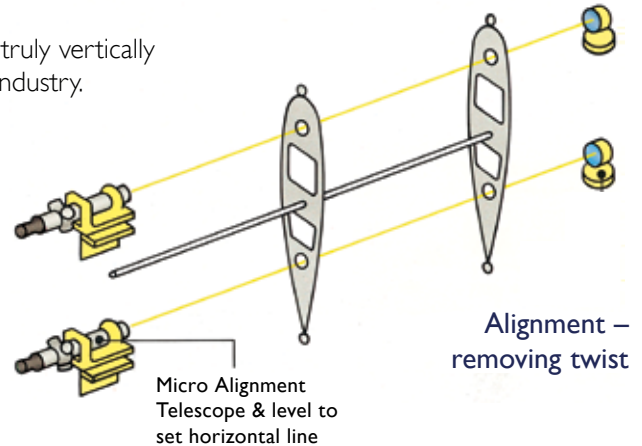

# Horizontal lines and flatness measurement

## Typical applications

- Engine bed plates: must be made flat so the top of the engine housing fits with the bottom bed plate.
- Bearing faces: need to be flat and parallel to each other to make a good fit.
- Rail systems: in some cases not only need to be parallel but also at the same height or plane to each other.

## Typical equipment used\*

- Micro Alignment Telescope (112-2582 or 112-2583)
- Horizontal Base (112-5820)
- Adjusting Bracket (112-5817)
- Flange Cup (112-471)
- Mounting Sphere (112-376 or 112-5823)
- Talyvel® (M112-4515),
- Stride Base (112-2315)
- Sphere Clamp (112-657),
- Flange Cup (112-471), Target (various) & Illuminator (112-5923)

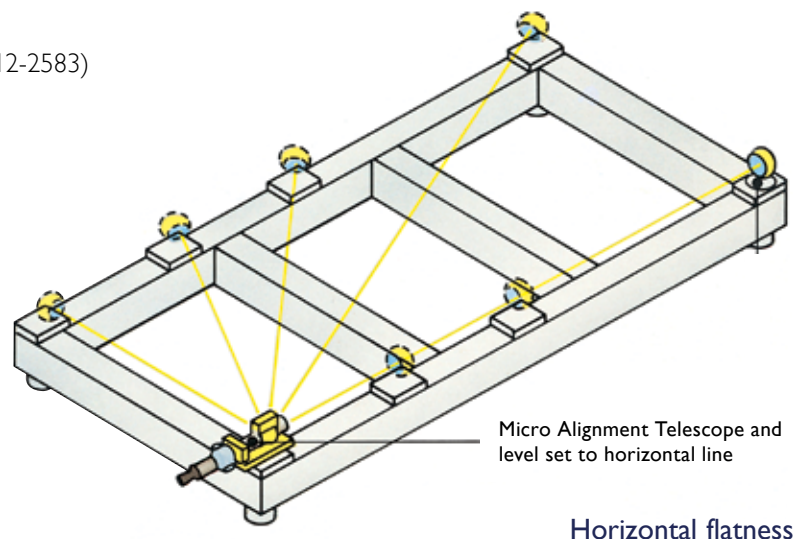

\* Additional items may be required – please consult your local Taylor Hobson representative.

# Straightness measurement

## Typical applications

- The large focusing range of the alignment telescope makes it ideal for checking long machine slideways.
- The rails in a submarine torpedo tube need to be set straight.
- Propellor shafts are getting increasingly long and the Alignment Telescope is ideal for this long distance bearing alignment work.

## Typical equipment used\*

- Micro Alignment Telescope (112-2582 or 112-2583) or Digital Micro Alignment Telescope (112-3389)
- Horizontal Base (112-5820)
- Adjusting Bracket (112-5817)
- Flange Cup (112-471)
- Mounting Sphere (112-376 or 112-5823)
- Target Holder
- Targets (various) and illuminator (112-5923)

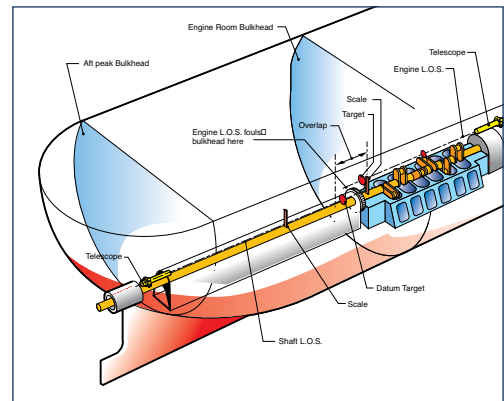

Propellor shaft alignment

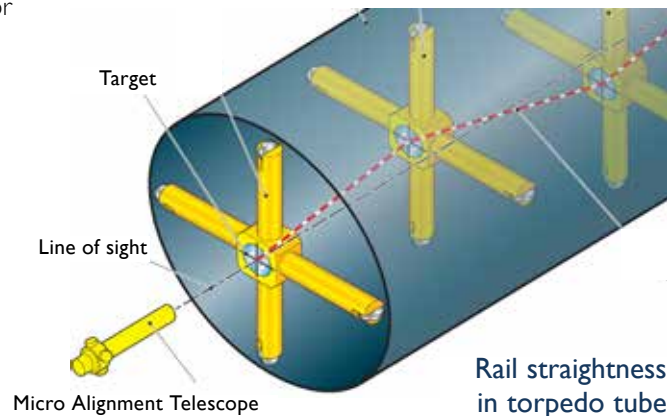

Rail straightness in torpedo tube

# Square and in line

## Typical applications

- Many weapons optical systems need to be set in line and square. The Alignment Telescope can be used in autocollimation mode to put things square and in alignment mode to put them in line. An Infra-red version of the Telescope is also available.
- Engine bearings to ships engine: the alignment telescope can be put in line and square with a mirror target using autoreflexion/ autocollimation and then other bearings put in line to this.
- Helicopter drive shafts must be put straight and square to their main drive system.

## Typical equipment used\*

- Micro Alignment Telescope (112-2582 or 112-2583)
- Lamphouse (112-5909)
- Horizontal Base (112-5820)
- Adjusting Bracket (112-5817)
- Mounting Sphere (112-376 or 112-5823)
- Adjustable Height Cup (112-849)
- Targets, including mirror target and holders).



Alignment on textile machines

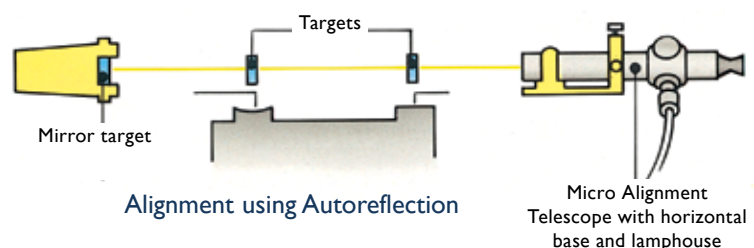

# The alignment systems range

## Digital Alignment Telescope (code 112-3389)

Using high resolution digital technology and dedicated software, the Alignment Telescope can be digitised to automatically calculate the displacement from a set datum to ensure fast set up and repeatable readings as well as digitally outputting the result. This is particularly useful on large alignment projects such as aircraft jigs or large machine tools since a single operator can make measurements and adjustments along the construction or fixture while the target is displayed on the monitor. (see further details on page 10)



## Micro Alignment Telescope (code 112-2582 Metric 112-2583 British)

The Micro Alignment Telescope focuses from zero to infinity and incorporates an optical micrometer to measure deviations from an optical line of sight in two directions at right angles to each other.

## Alignment Telescope (code 112-850)

Similar to the Micro Alignment Telescope but without the X and Y micrometers. Used when placing items in line where there is no need to take measured results.



## Micro Alignment Infra-Red system (Various codes)

This is a standard Micro Alignment Telescope but with source, coatings and camera for use in the infra-red.

## Short Barrelled Telescope (code 112-5896)

Similar to the 112-850 telescope this shorter 300mm version allows viewing in confined spaces. An optional 137-2161 camera with Vivi software can ease viewing further.

This telescope can be used with the standard targets in our range and can be mounted in V blocks. Custom mounting fixtures are available on request.



## Specifications

	Digital Micro Alignment Telescope	Standard Micro Alignment Telescope	Focusing Alignment Telescope	Infra-Red Telescope	Short Barrelled Telescope
Code	112-3389	112-2582, 112-2583	112-850	On application	112-5896
Max working distance	20 m	Infinity	Infinity	10 m	Infinity
Measuring range	50 mm	±1.2 mm *	none	±1.2 mm	None
Best accuracy **	5 µm	10 µm	10 µm	N/A	10 µm
Resolution	1 µm	10 µm	10 µm	N/A	10 µm
Targets	Dedicated target	See page 14	See page 14	Dedicated IR target	See page 14
Magnification	x34	x34 ***	x34 ***	N/A	x34 ***
Barrel diameter	57.137 – 57.147 mm	57.137 – 57.147 mm	57.137 – 57.147 mm	57.137 – 57.147 mm	44.43 – 44.44 mm

\* With the use of the calibrated glass targets this is increased.

\*\* At longer distances this is proportionally decreased by 50-70 µm at 30 m.

\*\*\* Higher magnifications can be achieved with the high magnification eyepiece (112-4940) or camera (137-2161-01).

# How to select the right accessories for the Micro Alignment Telescope System

## Select your alignment kit from these accessory items

To use the Micro Alignment Telescope you will need to select from a range of accessories. Should you need any advice on the precise accessories and components necessary, contact Spectrum Metrology or your local Taylor Hobson outlet.

1	Alignment Telescope *	See previous page
2	Right Angle Eyepiece Adaptor	112-568
3	Telescope Lamphouse	112-5909
4	Stride Base	112-5910
5	Stride Bubble	112-5911
6	Talyvel® 6 Electronic Level	M112-4515
7	Adjusting Bracket	112-5817
8	Horizontal Base	112-5820
9	Plain, Flange or Adjustable Height Cup	112-472, 112-471 or 112-849
10	Bore Fixture	112-5814
11	Mounting Sphere	112-376 or 112-5823
12	4 in Offset Square	112-1130
13	Optical Square	142-77
14	Spider Fixture	112-5813
15	Adjustable Mirror Target Holder	112-729
16	Adjustable Target Holder	112-5904
17	Targets (2.25 in / 57 mm) **	See page 14
18	Target Illuminator ***	112-5923
19	Mirror Targets **	See page 14
20	Targets (1.5 in / 38 mm) **	See page 14
21	Universal Stand	112-5824
22	Unimount ****	137-1916
23	Adjustable Tripod *****	112-4942

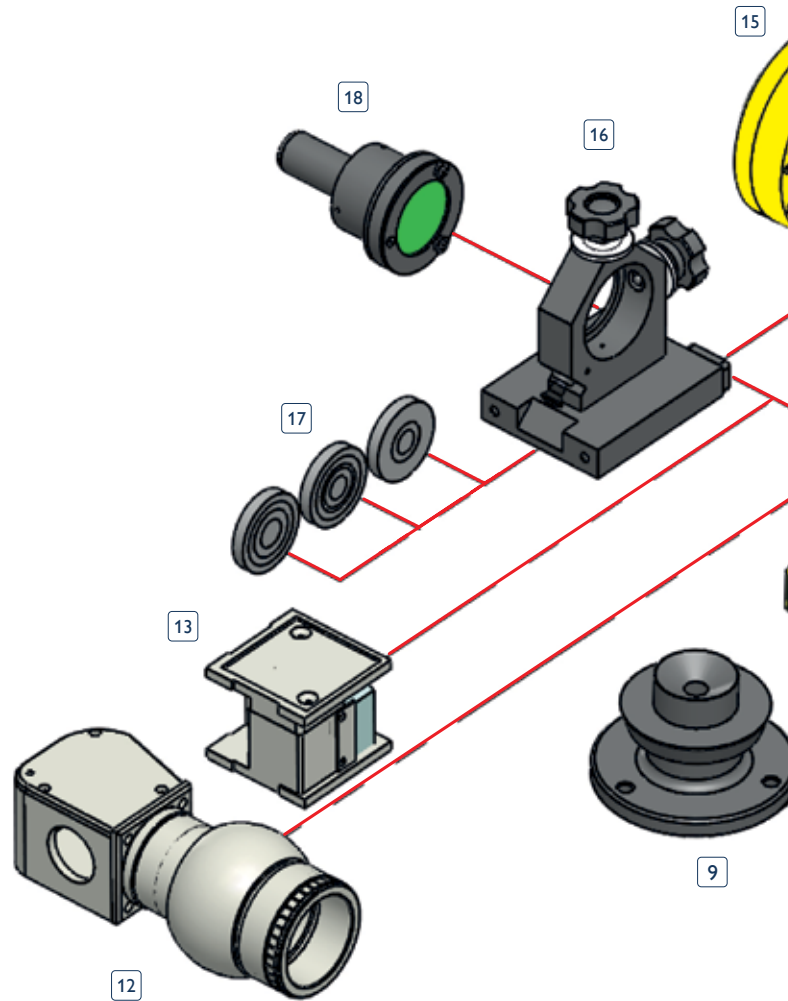

\* ViVi camera (137-2161) and high magnification eyepieces (112-4940) are available for higher magnification viewing.

\*\* Not suitable for use with the Digital Alignment Telescope which has a dedicated target. Targets can be made to order to suit individual applications.

\*\*\* Battery operated illuminator (112-5905) is also available.

\*\*\*\* A simpler version of unimount is available (112-5451).

\*\*\*\*\* Requires adaptor (112-4943) for use with flange cup.



Universal Stand



Unimount

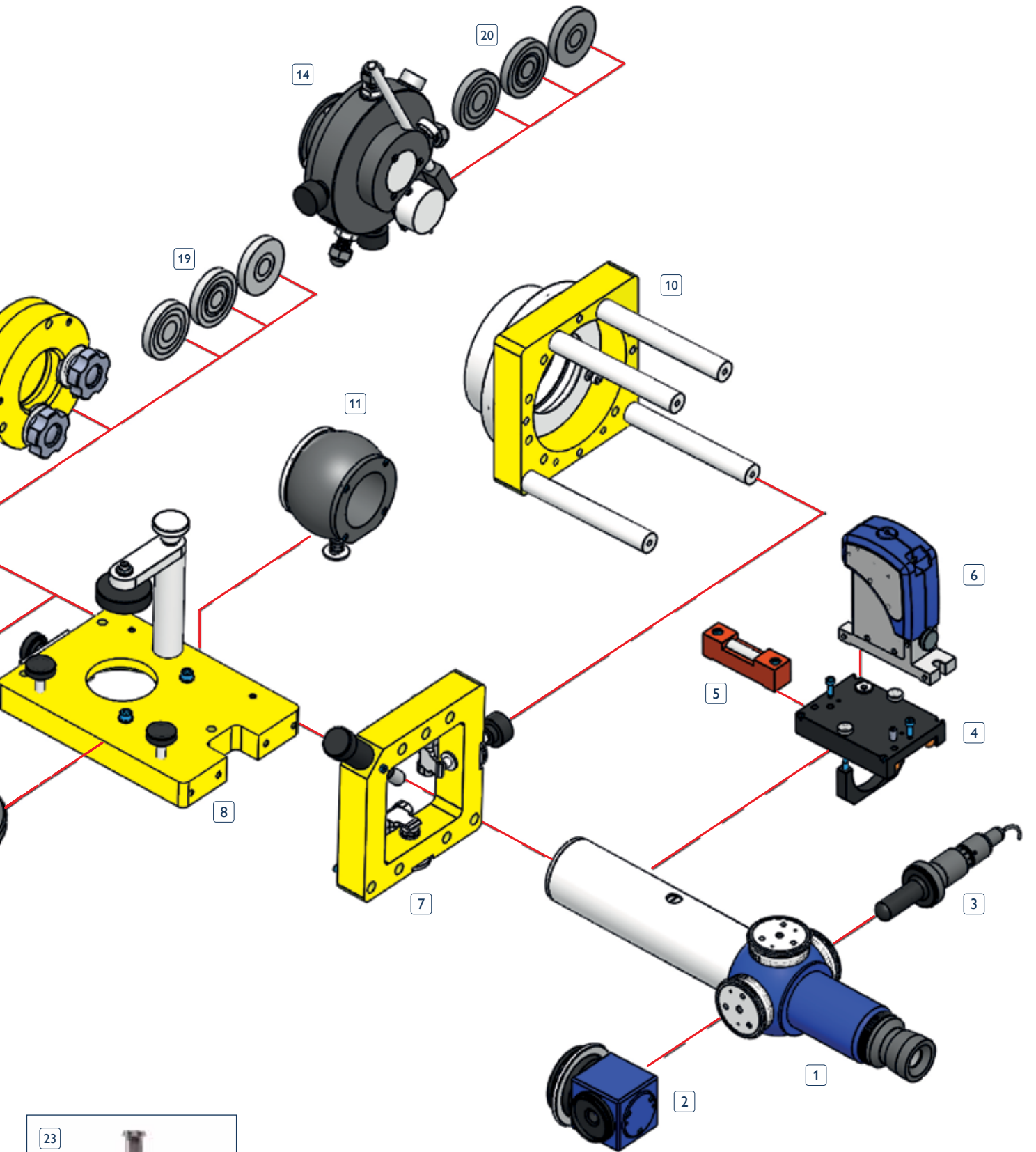

An adjustable tripod is available as an alternative to the unimount (Requires adaptor 112-4943)

# Micro Alignment Telescope accessories

## Digital DMAS camera (code 137-2160-01)

(connects to any Taylor Hobson Telescope)

Available as an accessory upgrade for existing Micro Alignment Telescopes in the field, a high resolution DMAS system with software automatically senses the centre position of the dedicated targets then calculates the displacement from a set datum to ensure a fast set up time with repeatable readings, as well as digitally outputting the result. This is particularly useful on large alignment projects such as aircraft jigs or large machine tools since a single operator can make measurements and adjustments along the construction or fixture while the target is displayed on the monitor.

- Clear digital output of X and Y minimises operator error
- Graphical output for reporting & storage of results
- Repeatability of measurement provided by digital camera
- Rapid calculation of results for quick and easy assessment
- Ideal for automatic remote monitoring with datalogging
- Typical accuracies: 5 µm over 3 m (decreasing with distance)

Target readings are recorded along the component and can then be output as a graph/results table or saved for further analysis. Analysis of the results can give advice on the required precise adjustment of the component under construction to bring it in line quickly.



137-2160-01 DMAS Digital System Accessory with software  
(112-3389 when ordered as a complete telescope system including 112-850 telescope)

## ViVi Camera (code 137-2161-01)

(connects to any Taylor Hobson Telescope)

- Choice of image magnifications up to x8
- Minimises eye fatigue
- Uses notebook PC with dedicated software
- Image can be viewed in difficult/awkward locations
- Minimises parallax error

A miniature camera can be fitted to the telescope eyepiece to remotely view the target when working for example in difficult locations. The camera features fine adjustment for focus and centring. A notebook/tablet PC is included with operator software that allows the user to magnify the target image from x2 up to x8. Templates can also be selected to aid with viewing and images can be saved to archive.

Viewing the target image on the monitor allows the operator to adjust the machine tool, targets or fixtures that require setting, without having to return to the Telescope each time

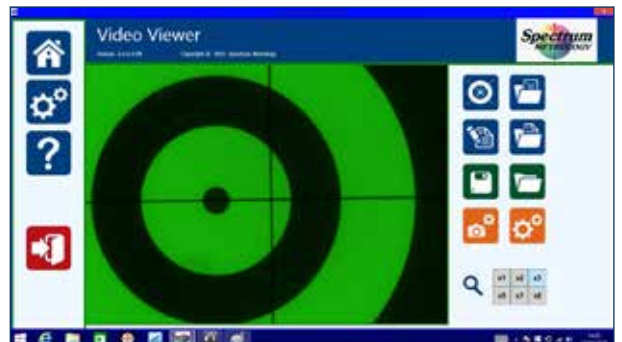

137-2161 ViVi accessory

## Right Angle Eyepiece Adaptor (code 112-568)

Enables the Telescope to be viewed at right angles to the line of sight. Especially useful where space is cramped or the sighting position inconvenient.



112-568 Right Angle Eyepiece

## High Magnification Eyepiece (code 112-4940)

Eyepiece with increased magnification is available which increases the eyepiece magnification to x50.

## Laser Alignment Aid (code 112-4941)

This attaches to the telescope barrel to speed up initial setting time in finding the target.



Customised cases are available.

These are padded and reinforced to absorb shocks. The case contains compartments to accommodate the Telescope and its accessories.

# Mounting the telescope

## Adjusting Bracket (code 112-5817)

Provides a fine azimuth and elevation adjustment for sighting the Telescope, used with a Horizontal Base or Bore Fixture.

## Horizontal Base (code 112-5820)

Used for mounting the Adjusting Bracket onto either the Plain, Flange or Adjustable Cup. When used on flat surfaces (plain cup), two fence pins provide a sideways location.

## Plain Cup (code 112-472)

Locates the Mounting Sphere on the Horizontal Base with its centre 73.5 mm (2.9 in) from the base of the Cup.

## Flange Cup (code 112-471)

Locates the Mounting Sphere on the Horizontal Base with its centre 110 mm (4.33 in) from the base of the Cup.

## Adjustable Height Cup (code 112-849)

Similar to code 112-471, but adjustable to height 110 mm  $\pm$  5 mm (4.33 in  $\pm$  0.188 in).

## Mounting Sphere (code 112-376)

The Mounting Sphere accepts either the Telescope or Target. Used on the Telescope it serves to provide a pivot when sighting the Telescope. The line of sight always passes through the Sphere centre.

A Collet Clamp key (code 116-27) serves any number of spheres.

## Bore Fixture (code 112-5814)

Used in conjunction with the Adjusting Bracket and Mounting Sphere to mount the Telescope in bores. The mounting diameter of 120.625-120.637 mm (4.7490-4.7495 in) is concentric with the Sphere.

## Universal Stand with rods (code 112-5824)

Used to mount the Telescope remotely from the work. up to approx 500 mm (19.7 in) height. Longer 1000 mm (39 in) rods also available code 112-5825.

## Tripod and adaptor (code 112-4942 & 112-4943)

Adjustable tripod with adjustment from 740 mm (29 in) to 1400 mm (55 in) height. Requires a 112-4943 adaptor to allow the 112-471 flange cup to be attached to the tripod (See photo on page 9).

## Unimount (code 137-1916)

This lightweight universal mounting system is used when using the Telescope remotely from the component to be measured. It is normally mounted on Trivet Stands to the required height and provides all the facilities for moving the Telescope through  $\pm 2.5^\circ$  elevation,  $\pm 2^\circ$  fine (360° coarse) azimuth, 100 mm (3.9 in) vertical, 76 mm (3 in) horizontal and 40 mm (1.6 in) sideways.

A simpler version is also available (code 112-5451), without backward/forward and rotational ability, suitable for standard alignment applications where the telescope only requires vertical/horizontal displacement and sideways/horizontal tilt.

## Levelling Base (code K510-3341)

A simple base which allows slight angular adjustment of  $\pm 3^\circ$ .



112-5817 & 112-5820  
(shown with sphere 112-5823, cup and telescope with right angle eyepiece)



112-471, 112-472 & 112-849

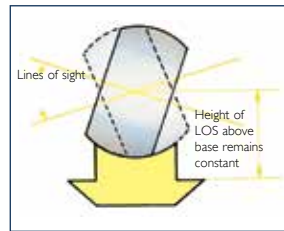

112-376



112-5814 (inc. 112-5817 & 112-5823)



112-5824



K510-3341

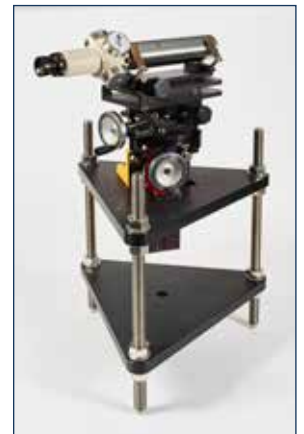

137-1916

# Mounting the target

## Sphere (code 112-5823)

Simple sphere used with a flange cup to mount a 2.25 in glass target (shoulder ring included).

## Target Illuminator\* (code 112-5923)

This accessory provides glare free background illumination for ideal viewing of the Target pattern.

The illuminator fits the sphere, shoulder ring, adjustable target holder and spider fixture. A battery operated version is also available. (code 112-5905). (Magnetic design - thread adaptors are available if used with older threaded target holders).

## Adjustable Target Holder (code 112-5904)

Normal height from base to centre of target 76 mm (3 in) and a range of vertical and horizontal adjustment of approx  $\pm 3$  mm (0.125 in). It has magnetic feet, can be located against fence pins and incorporates vertical and horizontal adjustment screws. Takes 2.25 in targets and is magnetic - thread adaptors are available if used with older threaded illuminators).

## Spider Fixture (code 112-5813)

Enables a target to be positioned in the centre of bores from 200 mm to 1 m (8-40 in). Larger diameter fittings to special request. Target centring is shown by a rotating dial indicator. The spider fixture is threaded to take the illuminator. Uses 1.5 in targets.



112-5823 sphere (shown with target illuminator and cup)



112-5904 (shown with target and illuminator)



137-5813 (shown with target in a demonstration ring)

# Setting a horizontal line

## Talyvel® 6 Electronic Level (code M112-4515) with Stride Base (code 112-5910)

Using the stride base, Talyvel is mounted on the Telescope barrel for setting horizontal lines of sight. Talyvel is a pendulum type Electronic Level, which provides a digital reading in angular measure or gradient. Typical accuracy setting is 0.2 arc second; ie 1  $\mu$ m per metre. For further details please refer to our Talyvel brochure.

## Bubble Vial (code 112-5911)

Used for establishing horizontal lines of sight, this is a precision bubble level used with 112-5910 base and mounted on the Telescope barrel. Accuracies of 5 seconds are obtainable. Other types of level are available on request, including methods to set truly vertical.



112-5910 & 112-5911 (shown mounted on telescope and base)

# Optical squares

These are used to deviate the Telescope's line of sight precisely 90° within 1 arc second; ie 5  $\mu$ m per metre. The 4 in offset square is mounted on the barrel of the Telescope. Rotated with the Telescope, it is used to sweep out planes perpendicular to the Telescope reference line of sight.

## Optical Square (code 142-77)

This optical square enables a 90° line of sight to be set up vertically or horizontally from the Telescope. The height of the sighting aperture is normally 76 mm (3 in) corresponding to the Plain Cup mounting height for the Telescope. A reduced specification version (code 142-212) is also available.

Can be used with the 112-5439 adjustable table. This allows the square to be finely tilted and adjusted accurately when measuring bed to column squareness or horizontal slide parallelism in the azimuth direction.



Talyvel® 6 M112-4515



Optical square 142-77 (on adjustable base 112-5439)

## 4 in Offset Square (code 112-1130)

Has its 90° line of sight 4 in (102 mm) forward of its mounting sphere and is used to sweep the full 360°. It has a through sighting facility, enabling the reference target to be viewed at all times.

Other accessories and types of squares are available on request such as devices for sweeping a plane.

## Autoreflexion and autocollimation\*

When fitted with a lamphouse, the Micro Alignment Telescope can be used for setting or checking squareness, and measuring small gradients of tilt, by autoreflexion or autocollimation.

### Telescope Lamphouse (code 112-5909)

Inserted into the Telescope to illuminate the integral cover glass target, it has a partially reflecting mirror that does not obscure the line of sight. Power supply included.

### Adjustable Mirror Target Holder (code 112-729)

For mounting a Mirror Target on the end of a rotating spindle or shaft. The two adjusting screws enable the mirror target to be tilted so that the spindle axis can be aligned with the Telescope line of sight, using Autoreflexion. Has a 95.25 mm (3.75 in) diameter locating spigot concentric with the Target pattern.

### Squaring-On Reflector (code 112-722)

Assists in preliminary lining up of the workpiece when the Autoreflexion image is initially outside the Telescope field of view. Two images are seen through the viewing aperture and these converge as the workpiece is brought square to the line of sight.

## Setting a vertical line of sight

### Vertical Base (code 112-4945)

Used for setting a true vertical line of sight. Requires a bore fixture with adjusting bracket and sphere. The bore fixture adaptor contains a mirror that can be levelled with a Talyvel differential system (not included). The mirror is set truly horizontal then the MAT is set square to it, producing the vertical reference line. Typical applications include setting refuelling rods truly vertical and setting defence platforms to gravity.

## Telescope Calibration Equipment

Intended for users who wish to carry out their own calibration check on their Telescopes, including variable focus collimator (code 137-583), rotating Test Wedge (code 137-829) and Micro Alignment Telescope bench (code 137-1917). Parallelism of the Telescope line of sight with respect to the barrel of the Telescope is checked by sighting into the Variable Focus Collimator and revolving the Telescope through 180°.

The variable focus of the collimator simulates all focal distances, enabling the straightness of the Telescope line of sight to be checked. The graduated scale target on the front of the collimator is used for checking concentricity of the Telescope line of sight to its barrel, and also linearity of the Telescope micrometers. The test wedge is used to measure the angle of parallelism.

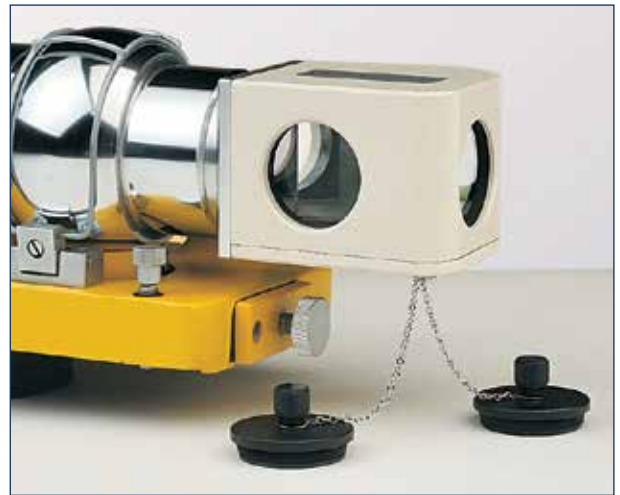

112-1130



112-5909



112-729 (shown with mirror target)



137-1917

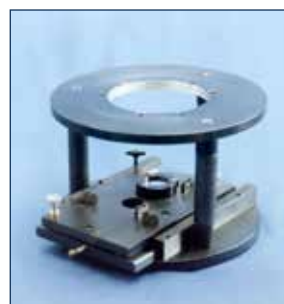

112-4945

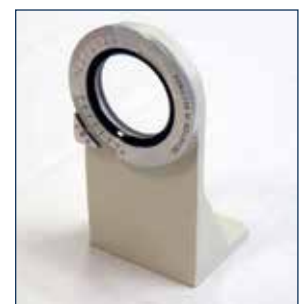

137-829

\* Digital Micro Alignment Telescope (code 112-3389) cannot measure in this mode.

# Targets\*

The targets listed below are available for various applications. All targets have a parallelism within 2 arc seconds, minimizing possible refraction errors. Mirror targets are used when both alignment and squareness are checked concurrently using autoreflection or autocollimation. Other targets are available on request.

Nominal diameter	Type	Pattern	Parallelism	Use	Code	
					British	Metric
57 mm	Target	Standard circular	2	Intermediate target	112-1052	112-1058
38 mm	Target	Standard circular	2	Intermediate target	112-1050	112-1056
57 mm	Long distance	Long distance circular	2	25-75 m (80 ft-250 ft)	112-856	-
57 mm	Long distance	Standard circular	2	60-135 m	112-857	-
57 mm	Mirror target	Standard circular	2	Back face location	112-1054	112-1060

- 1.5 in target Diameter: 38.075-38.087 mm (1.4990-1.4995 in)  
Thickness: 9.27-9.78 mm (0.365-0.385 in)
- 2.25 in target Diameter: 57.132-57.148 mm (2.2493-2.2498 in)  
Thickness: 12.45-12.95 mm (0.490-0.510 in)

Pattern concentric with outside circumference of target:-  
 Long distance targets: within 0.0127 mm (0.0005 in).  
 All other targets within 0.0064 mm (0.00025 in)  
 Special targets are available on request.

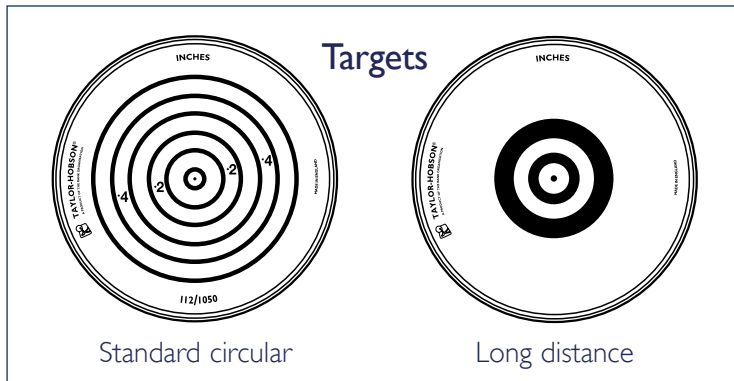

## Special applications

In addition to the range of standard accessories shown in this brochure, equipment can be designed or manufactured to special order to meet specific applications, for example to set the Micro Alignment Telescope truly vertical.

Contact our technical support agent, Spectrum Metrology, or your local Taylor Hobson representative for details.

## Industry applications

Many applications which have utilised the Taylor Hobson range of Micro Alignment Telescopes are the subject of application reports, including:

- Technical note T129: Pipes (Measuring perpendicularity and parallelism of pipe end faces)
- Technical note T128: Machine Tools (Electro optical metrology in the machine tool industry)
- Technical note T132: Aircraft (Electro optical metrology in the aircraft industry)
- Technical note T133: Defence (Electro optical metrology in the defence industry)
- Technical note T147: Shipbuilding (Electro optical metrology in the shipbuilding industry)
- Industry note A152: Engine (Alignment, checking and setting of engines, turbines and generators)
- Industry note A144: Railway (Electro optical metrology in the railway industry)
- Industry note A151: Helicopters (helicopter applications for Micro Alignment Telescope)
- Technical note T148: Submarine (Electro optical metrology in submarines)
- Industry note A154: Roller (Checking level and parallelism during roll system installation and maintenance)
- Industry note A150: Optics (Electro optical metrology in the optical industry)

## Training and calibration

### Training

Detailed training courses are available either on-site or at Spectrum Metrology's facility in Leicester, UK. Price on application.

### UKAS Certification

Micro Alignment Telescopes can be supplied with a United Kingdom Accreditation Service (UKAS) certificate which gives an independent and authoritative traceable guarantee of instrument performance and accuracy. Regular servicing and UKAS calibration will guarantee that the performance specification is maintained.

# Distance measurement

This laser distance meter is used in conjunction with the Micro Alignment Telescope or as a stand-alone system. Comprising a portable meter with dedicated software and optional target, this easy to use unit can be used to set or measure a precise distance of up to 30 metres, to an accuracy of 2 mm.

The laser distance meter is particularly useful where there is an interrupted surface to be measured (such as in shipbuilding or engine alignment applications) which are difficult to measure manually.

In its simplest form the distance meter plugs into a laptop and the white faced target code 112-5656-01 (or similar artefact) is moved to the required position. The laser in the distance meter reflects off the target and the result is displayed on the software screen. The target can then be adjusted until the required distance is achieved.

For a fully digitised system, the distance meter can be run in conjunction with the Micro Alignment Telescope with DMAS digital software to allow accurate setting of target positions for more repeatable alignment checks. The distance readings can be recorded in the DMAS software, increasing the repeatability of the alignment readings.



Distance measurement

## Distance Measurement Accessory

(code 112-5653)

Distance Measurement Accessory comprising measurement head, laptop and distance software (stand-alone distance measuring device).



Distance measurement software when used as a standalone item

## Distance Meter including Micro Alignment Telescope (code 112-5654)

Distance Meter including Micro Alignment Telescope and CCD package (DMAS).

## Distance Meter with DMAS (code 112-5655)

Distance Meter with (DMAS) software upgrade (for use with existing Micro Alignment Telescope and DMAS package).

## White distance target (code 112-5656)

Optional distance target to focus the beam of the distance meter.



Distance measurement option when used with the DMAS software



Distance meter on Micro Alignment Telescope

## The Metrology Experts

Established in 1886, Taylor Hobson is the world leader in surface and form metrology and developed the first roundness and surface finish measuring instruments.

[www.taylor-hobson.com](http://www.taylor-hobson.com)

## Sales department

Email: [taylor-hobson.sales@ametek.com](mailto:taylor-hobson.sales@ametek.com)

Tel: +44 (0) 116 276 3771

- **Design engineering** – special purpose, dedicated metrology systems for demanding applications.
- **Precision manufacturing** – contract machining services for high precision applications and industries.

## Centre of Excellence department

Email: [taylor-hobson.cofe@ametek.com](mailto:taylor-hobson.cofe@ametek.com)

Tel: +44 (0) 116 276 3779

- **Inspection services** – measurement of your production parts by skilled technicians using industry leading instruments in accord with ISO standards.
- **Metrology training** – practical, hands-on training courses for roundness and surface finish conducted by experienced metrologists.
- **Operator training** – on-site instruction will lead to greater proficiency and higher productivity.
- **UKAS calibration and testing** – certification for artifacts or instruments in our laboratory or at customer's site.

## Service department

Email: [taylor-hobson.service@ametek.com](mailto:taylor-hobson.service@ametek.com)

Tel: +44 (0) 116 246 2900

- **Preventative maintenance** – protect your metrology investment with an AMECare support agreement.



© Taylor Hobson Ltd. 2020



### Taylor Hobson UK

(Global Headquarters)

PO Box 36, 2 New Star Road  
Leicester,  
LE4 9JQ,  
England

Tel: +44 (0)116 276 3771  
[taylor-hobson.sales@ametek.com](mailto:taylor-hobson.sales@ametek.com)



### Taylor Hobson France

Rond Point de l'Epine Champs  
Batiment D, 78990 Elancourt, France  
Tel: +33 130 68 89 30  
[taylor-hobson.france@ametek.com](mailto:taylor-hobson.france@ametek.com)



### Taylor Hobson Germany

Rudolf-Diesel-Straße 16,  
D-64331 Weiterstadt, Germany  
Tel: +49 6150 543 0  
[taylor-hobson.germany@ametek.com](mailto:taylor-hobson.germany@ametek.com)



### Taylor Hobson Italy

Via Della Liberazione 24, 20068, Peschiera  
Borromeo, Zelofoaramagno, Milan, Italy  
Tel: +39 02 946 93401  
[taylor-hobson.italy@ametek.com](mailto:taylor-hobson.italy@ametek.com)



### Taylor Hobson India

Divyasree NR Enclave, 4th Floor, Block A,  
Plot No. 1, EPIP Industrial Area, Whitefield,  
Bengaluru - 560066, India  
Tel: +91 80 6782 3346  
[taylor-hobson.india@ametek.com](mailto:taylor-hobson.india@ametek.com)



### Taylor Hobson China

[taylor-hobson-china.sales@ametek.com](mailto:taylor-hobson-china.sales@ametek.com)

#### Shanghai Office

Part A1, A4, 2nd Floor, Building No. 1, No. 526  
Fute 3rd Road East, Pilot Free Trade Zone,  
Shanghai, 200131, China  
Tel: +86 21 5868 5111-110

#### Beijing Office

Western Section, 2nd Floor, Jing Dong Fang  
Building (B10), No. 10, Jiu Xian Qiao Road,  
Chaoyang District, Beijing, 100015, China  
Tel: +86 10 8526 2111

#### Chengdu Office

No. 9-10, 10th floor, 9/F, High-tech Incubation  
Park, No. 160, Jinyue West Road, Chengdu  
610041, China  
Tel: +86 28 8675 8111

#### Guangzhou Office

Room 810 Dongbao Plaza, No.767 East  
Dongfeng Road, Guangzhou, 510600, China  
Tel: +86 20 8363 4768



### Taylor Hobson Japan

3F Shiba NBF Tower; 1-1-30, Shiba Daimon  
Minato-ku, Tokyo 105-0012, Japan  
Tel: +81 34400 2400  
[taylor-hobson.japan@ametek.com](mailto:taylor-hobson.japan@ametek.com)



### Taylor Hobson Korea

#309, 3rd FL, Gyeonggi R&DB Center; 105,  
Gwanggyo-ro, Yeongtong-gu, Suwon-si,  
Gyeonggi-do, Korea, 16229  
Tel: +82 31 888 5255  
[taylor-hobson.korea@ametek.com](mailto:taylor-hobson.korea@ametek.com)



### Taylor Hobson Singapore

AMETEK Singapore, 10 Ang Mo Kio Street 65,  
No. 05-12 Techpoint, Singapore 569059  
Tel: +65 6484 2388 Ext 120  
[taylor-hobson.singapore@ametek.com](mailto:taylor-hobson.singapore@ametek.com)



### Taylor Hobson Thailand

89/45, Moo 15, Enterprise Park, Bangna-Trad  
Road, Tambol Bangkaew, Amphur Bangplee,  
Samutprakarn Province 10540, Thailand  
Tel: +66 2 0127500 Ext 505  
[taylor-hobson.thailand@ametek.com](mailto:taylor-hobson.thailand@ametek.com)



### Taylor Hobson Taiwan

10F-5, No.120, Sec. 2, Gongdao Wu Rd.,  
Hsinchu City 30072, Taiwan  
Tel: +886 3 575 0099 Ext 301  
[taylor-hobson.taiwan@ametek.com](mailto:taylor-hobson.taiwan@ametek.com)



### Taylor Hobson Mexico

Acceso III No. 16 Nave 3 Parque Ind. Benito  
Juarez Queretaro, Qro. Mexico C.P. 76120  
Tel: +52 442 426 4480  
[taylor-hobson.mexico@ametek.com](mailto:taylor-hobson.mexico@ametek.com)



### Taylor Hobson USA

27755 Diehl Road, Suite 300, Warrenville,  
IL 60555, USA  
Tel: +1 630 621 3099  
[taylor-hobson.usa@ametek.com](mailto:taylor-hobson.usa@ametek.com)



1100 Cassatt Road, Berwyn, PA 19312, USA  
Email: [info.corp@ametek.com](mailto:info.corp@ametek.com)  
Web: [www.ametek.com](http://www.ametek.com)